



MVP 410 • 440

The Sonicu MVP 410 and MVP 440 Temperature Meters are state-of-the-art wireless workhorses that are fully adaptable to virtually any temperature/humidity measuring and monitoring application.

SONICU SOLUTION

Both units accept a variety of temperature and humidity probes ranging from ambient relative humidity to CDC-recommended glycol-buffered medical-grade devices, cryogenic and ULT probes for medical, research, bio-medical and other specialized applications.

The MVP 410 and MVP 440 are fully digital, operate on rechargeable battery or AC power and incorporate micro SD memory storage in conjunction with Sonicu's Data Sync feature, which virtually eliminates data loss due to power outage or other interruption.

Multiple networking capabilities allow several units to be meshed into a unified system via 900 MHz with data transmission directly to Sonicu's cloud-based software platform by 4G cellular, Wi-Fi or Ethernet, operating either in conjunction with or independently of existing enterprise IT systems.

Alerts and alarms can be sent via text, phone call or email to designated recipients based on user-defined parameters.

OUR ADVANTAGES

- Digital technology reduces costs and downtime associated with recalibration
- Sensor-to-cloud data transmission requires no additional hardware or software
- On-board memory can store five-years worth of data at 15-minute monitoring intervals
- Adaptable to a variety of applications simultaneously for maximum flexibility
- Fully configured, easy to deploy and completely scalable
- Industry-leading battery life up to five years
- UPS mode (main power from wall adapter; switches to battery during power outages.) Can be configured to report battery voltage and/or power loss from wall adapter
- Device connectivity reports ensure all data packets are being transmitted

APPLICATIONS & INDUSTRIES

Sonicu's MVP 410 and MVP 440 Temperature Meters monitor and measure humidity and ambient, ultralow and cryogenic temperatures for Healthcare, Research/Laboratories, Food Services, Industrial, and Facility Monitoring.



Sonicu provides access, alarming and archiving 24/7/365 via any internet-enabled device.

Features **MVP 410 • 440**

Specifications

External Ports	MVP 410 – single port MVP 440 – four ports
Construction	ABS plastic housing
Dimensions	410: 3.355" x 4.25" x 1.357" 440: 3.071" x 5.254" x 1.450"
Radio Protocols	4G Cellular, Wi-Fi 802.11 b/g/n, 900 MHz (meshing)
Power Modes	2600 mAh Li-ion 3.7v rechargeable battery 12v DC wall adapter
Enterprise Security	Wi-Fi: WPA2; Cellular: standard encryption to tower, virtual private network to cloud, completely secure
Operating Temp	-10 C to +40 C
Humidity	10 to 95% RH, non-condensing
Cables	Flat 6-ft, 15-ft and 25-ft
Mounting	Adhesive or screw mount
Warranty	Warranted for duration of Data Service Agreement

Part numbers **Description**

101207	MVP-410-WiFi
101208	MVP-410-Cell (4G LTE)
101206	MVP-410-900 MHz
101210	MVP-440-WiFi
101211	MVP-440-Cell (4G LTE)
101209	MVP-440-900 MHz

Probes

100234	Glycol Digital Snap, -55 C to +40 C
100180	Air Digital Snap, -55 C to +125 C
101212	Humidity and Temperature Digital
100260	ULT Digital 4" Stainless Sheath, -100 C to 0 C
100261	Cryogenic Digital 15.5" Stainless, -205 C to -105 C

Accessory Parts

100040	Power Wall Adapter: 12V DC
100274	Flat 6-foot cable
100280	Flat 15-foot cable
100281	Flat 25-foot cable

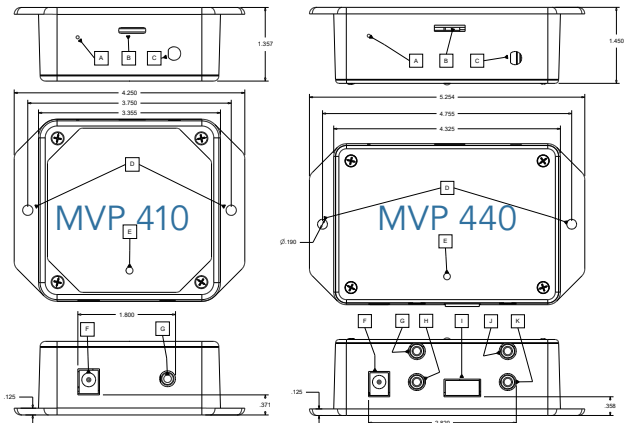

Any Department. **Any** Application. **One** Choice.